



# Floating Attachment

In many applications, for example when depalletizing, the exact vertical position of the products to be lifted may not be known. Variations may be due to the relative position of lower layers or if there have been movements during transport. The vertical position may be known with accuracy of a few centimeters, but to know more accurately a vision system may be needed, which could also increase the cycle time. Also, if a layer of products are handled, the layer may be skewed and for ideal lifting power, the UniGripper lifting plate should be slightly tilted. With the floating attachment, these potential issues are solved in a simple and economical way.

Sensor bracket

Floating attachment plate

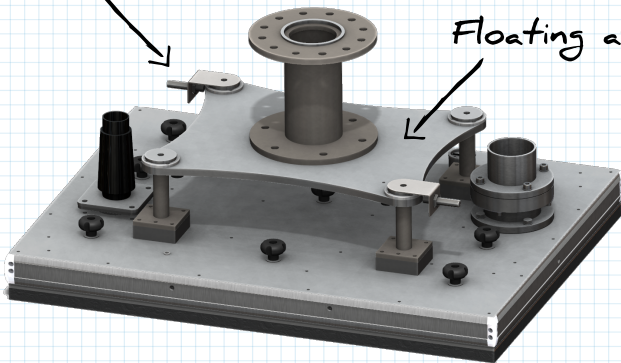

*Floating attachment in upper position*

## Sensors

The floating attachment can be equipped with sensors that give an indication when the floating attachment plate gets closer to the UniGripper plate. The robot then gets informed that the Unigripper is on the product and that vacuum can be applied.

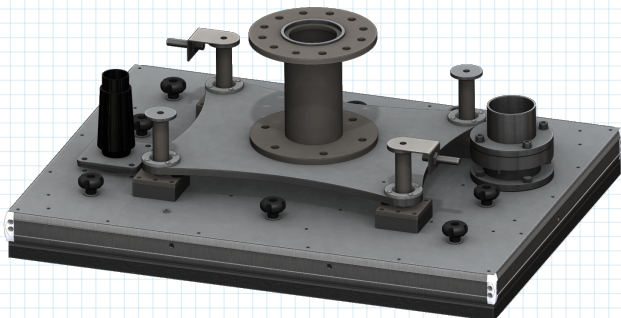

*Floating attachment in bottom position*